



DRIVEN BY POSSIBILITY™

FOOD & BEVERAGE REFERENCE GUIDE

**WHATEVER YOU'RE
PACKING, WE'RE PACKING
THE KNOW-HOW**





TOTAL PACKAGING KNOWLEDGE FOR THE FOOD & BEVERAGE SECTOR

At Gates, we offer packaging machinery part solutions across multiple sectors, industries and markets – and when it comes to F&B, there's no one better to have on your side. From product handling and processing to material handling and packaging, we can help you stay optimized, productive and above all, profitable.

F&B: THE BIG PICTURE...

- High consumption of processed and packaged food, worldwide and significant demand for ready to eat, ready to cook packaged food – increasing the need for packaging machinery in F&B
- Urbanization, technological developments and F&B purchasing power
- Growing awareness about contamination and safety in food production



THE **TOTAL** GATES SOLUTION

Whether you're responsible for manufacturing packaging machinery or maintaining efficiencies and plant uptime, Gates easy to clean food conveyor belts and components are able to meet your needs.

HOSE SPECIFIC SOLUTIONS

- Gates MXT™ - XTP hoses are lighter and more flexible, and lower equipment weight and size
- Simplified inventory system approach – including fittings and crimpers for all common applications: air, water, washdown, pressure wash and hydraulic
- Gates MegaTuff™ Covers – excellent hose cover for F&B environments due to denser structure to lock out bacteria and make cleanup easier. Plus, more abrasion resistant, without trapping bacteria

WE PACK CHAIN-TO-BELT EXPERTISE AND KNOW-HOW

- Reduced maintenance and downtime – no retensioning and no stretch leading to link removal and less frequent sprocket replacement
- Improved HSE – no oil baths or lubrication, eliminates potential contaminants

PACKED WITH TPU SPECIFIC EXPERTISE

- Food conveyor belt range – food-grade belts: USDA certified and meets FDA and EU food regulations and food processing industry specifications
- Complete product line – endless welded belts, endless Flexbelt, belts with backing and profiles, wide belt
- Corrosion resistant WR belt series – with durable and encapsulated cords – allows for direct contact with food



SPECIAL BELTS DESIGNED FOR CONTACT WITH FOOD: POSICLEAN, CENTERCLEAN AND FLATCLEAN

- Direct replacement for plastic modular belts
- Great for troughing
- Can clean-in-place

OUR TPU BELTS PRODUCTS PORTFOLIO:

ALWAYS THINKING OUTSIDE THE BOX

Serving applications in synchronous and positive drive conveying, linear positioning, and power transmission, Gates TPU bring you high quality, abrasion-resistant polyurethane – for safe, clean, productive, fully optimized F&B operations.

1. FOLDING / GLUER AND CASE PACKING

This machinery is typically used to erect cartons or paperboard boxes. Loads are generally lightweight, but need to be held in place so that they can be accurately folded, glued, and filled.

Primary individual packages are then collated into cases making precise linear positioning critical.

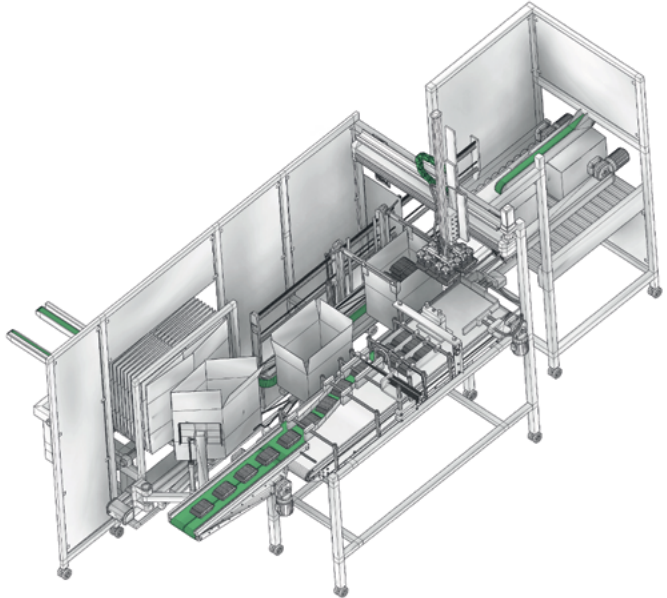

WELDED ENDLESS LINEAR BELT AND WIDE BELT WITH OPTIONAL BACKING

- Fully flexible - backings can adjust the level of friction/grip, to customize the belt to the specific application

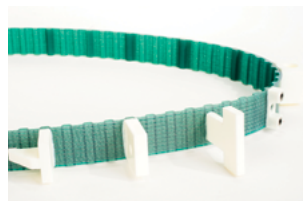

WELDED ENDLESS LINEAR BELT WITH PROFILES

- Perfectly precise – helps you with accurate indexing
- Helping hand – holds items while being packed and sealed
- Simplified system – distributes conveying food
- Maximum efficiency – start / stop action without loss of position



OPEN-ENDED LINEAR BELT

- Total precision – motion control moves robotic machinery back and forth, whilst suction cup grabs paperboard

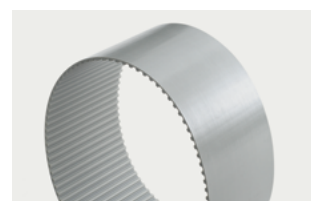

TRULY ENDLESS SLEEVES

- Complete customization – use of CNC machining to create holes for Vacuum Belt functionality holds down bags as they are filled

2. FILLING AND WRAPPING

Machinery will vary depending on industry and product type. Typically, the filling process will wrap or fill the raw product into primary packaging, making precise product indexing and a clean working environment critical.

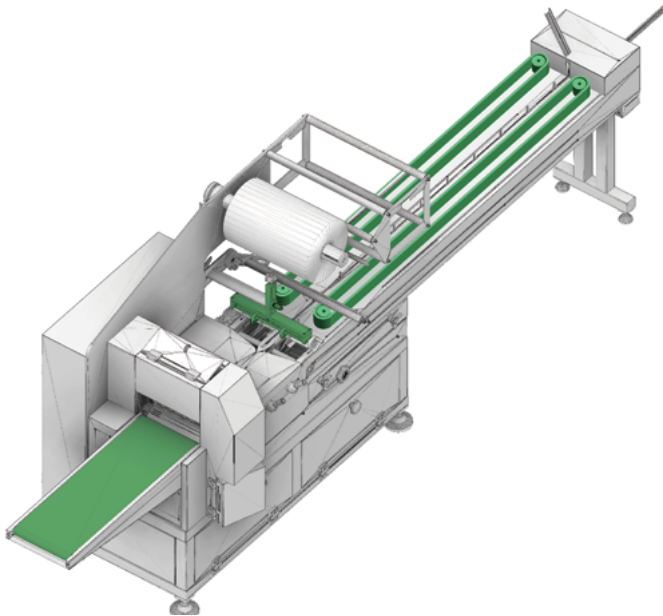

OPEN-ENDED LINEAR BELT

- Precise motion control – for small and precise wrapping and to grab paperboard

WELDED ENDLESS LINEAR BELT/WIDE BELT – WITH OPTIONAL BACKING AND PROFILES

- Improved process – abrasion resistant backings to withstand sharp edges and assist with tight conveyor transfer
- Everything in place – profiles to assist in keeping raw materials to uniform amounts before packaging

FOOD BELTS – POSICLEAN, CENTERCLEAN AND FLATCLEAN

- Specific usage – all designed for direct contact with food
- Broad application – direct replacement for most plastic modular belts
- Added benefits – appropriate for troughing and ability to clean-in-place

3. SEALING AND LABELING

At the end of the packaging process, welded endless and truly endless belts can be used to apply labels or final seals. Holding the packaging still and in the correct position is critical at this stage.

WELDED ENDLESS LINEAR BELT/WIDE BELT WITH OPTIONAL BACKING

- Improved process – abrasion resistant backings to withstand sharp edges and assist with tight conveyor transfer
- Precise motion control – allows the belt to hold the package steady to apply uniform seal or label

TRULY ENDLESS SLEEVES

- Complete customization – use of CNC machining to create holes for Vacuum Belt functionality
- Optimized operation – pulls down bags while they are filled

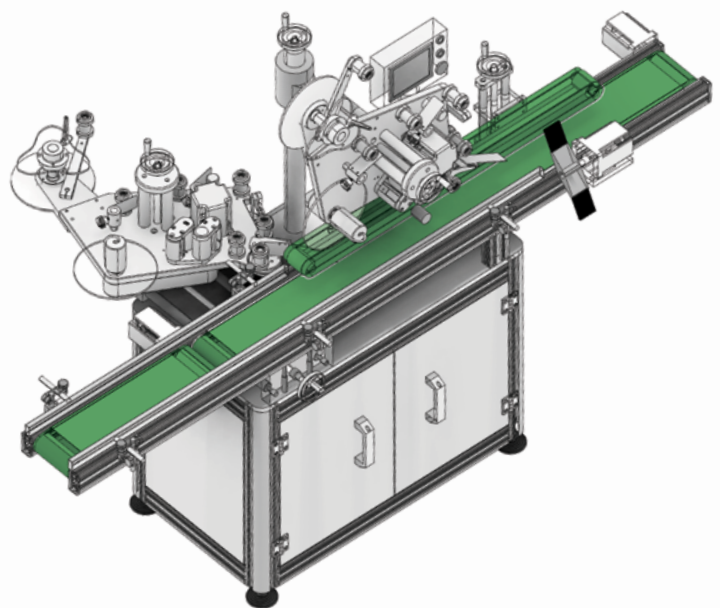

HOSES PACKED WITH EVEN MORE BENEFITS

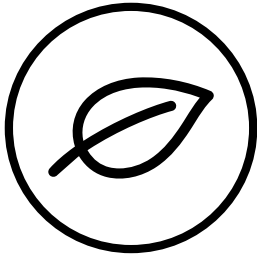

FIND THE PERFECT HOSE

Application engineering support can help you find the best hose for your solution, including one compatible with your food and beverage needs



YOU'RE COVERED

MegaTuff - locks out bacteria and makes cleanup easier



BOTTLE BETTER

Premium™ Dairy Master - the lifeline of your food processing operation



GET TOTAL REASSURANCE

Clean Master™ Plus Pressure Wash - exceeding EN 1829-2 standard

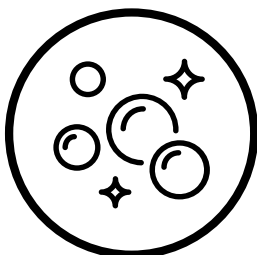

KEEP THINGS CLEAN

Clean Master Washdown 1000 - non-marking cover resistant to oil and animal fat





APPLICATIONS

Gates meets the needs of the packaging industry by offering a variety of products for use on different types of applications. All our products have one thing in common: they solve a wide range of problems to help you meet production and efficiency goals while saving money.

POWER TRANSMISSION	PRODUCT TRANSFER	FACILITY WASHDOWN
<p>SYNCHRONOUS BELTS</p> <p>Poly Chain® Carbon Volt PowerGrip™ GT4™ Synchro-Power™</p>	<p>SYNCHRONOUS BELTS</p> <p>Long Length</p>	<p>INDUSTRIAL HOSES</p> <p>Clean master washdown Clean master washdown 1000 Clean master Pressurewash Washdown master</p>
<p>V-BELTS</p> <p>Quad-Power™ 4</p>	<p>TPU BELTS</p> <p>TPU endless belt with backings TPU endless belt with profiles TPU endless vacuum belt TPU food conveyor belt TPU endless wide belt</p>	
<p>HYDRAULIC HOSE ASSEMBLIES</p> <p>MegaSys™ MXT-XTP MegaTuff (MTF) covers</p>	<p>INDUSTRIAL HOSES</p> <p>Premium Dairy Master SD Dairy Master Lite SD Milk Master SD Beverage Master D</p>	



DRIVEN BY POSSIBILITY™

WE THINK **OUTSIDE** THE BOX, SO YOU AND YOUR CUSTOMERS CAN **FOCUS** ON WHAT GOES **INSIDE** IT

As safe and clean as you need products to be to ensure complete peace of mind for direct food handling and contact, Gates F&B expertise is second to none:

- 100% in-house production for the complete technical solution
- Longer life means lower total cost of ownership
- Food contamination-free for the F&B industry
- Delivering products that exceed customer expectations, our Eco-Innovation™ System helps advance positive impacts of end-user applications
- Endless belt fits diverse packaging requirements
- Engineering support from initial design to trainings and site surveys
- Peace of mind with products meeting all USDA and EU regulations

THE QUALITY AND REASSURANCE YOU DESERVE



APPLICATION KNOW-HOW

technical experts work with your team to deliver solutions to meet your needs



EXPERTISE

dedicated team to answer questions, provide training and solve challenges



QUALITY

deliver performance and reliability as expected from Gates globally



RESPONSIVENESS

flexible regional teams, close to you and provide hands-on service where you need it

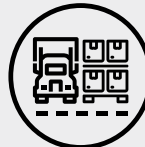

DELIVERY

short lead times delivered on time, setting industry standards

READ OUR **OTHER REFERENCE GUIDES** TO SEE HOW WE PACK THE KNOW-HOW ACROSS ALL SECTORS AND INDUSTRIES.

GATES.COM
JANUARY 2024

