



TPU BELTS

THERMOPLASTIC POLYURETHANE

REPLACEMENT FOOD GRADE FORM

*Name:	*Phone:	*Email:
*Company Name:	*Site Location:	
*Briefly describe what is being replaced:		

Fill out one of the three lines below

*Max. Load:	lbs.		
*Load Rate:	lbs/hr	and	Conveyor Speed: ft/min
*Lb per cubic foot:		and	Depth of Product: in

Belt Pitch:	
Belt Width:	
Belt Length:	
Splice Type	
Mechanical:	Weld:
Straight Cleats (5mm thick)	
Height:	Spacing:
Scoop Cleats (7mm thick)	
Height:	Spacing:
Sidewalls:	
Height:	
Offset of Cleat/Sidewall (in/mm):	
Application Wet or Dry?:	

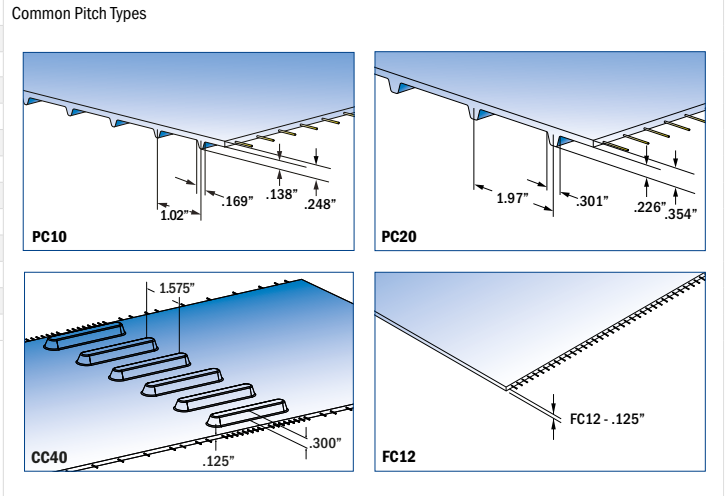

*Measurements are between sprockets, center to center

STRAIGHT CONVEYOR

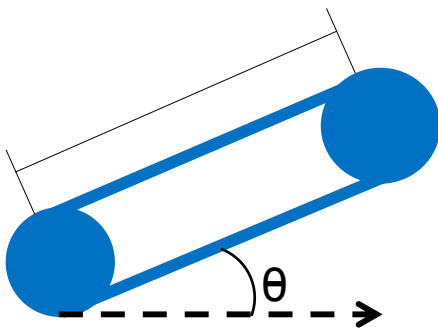

Z-CONVEYOR

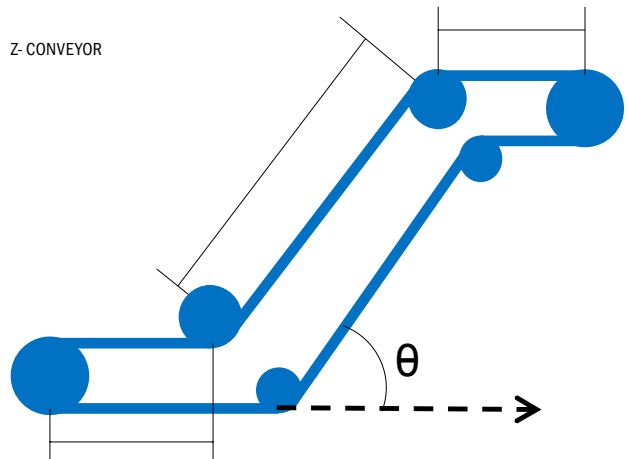

*Sprocket information only needed if changing pitch

ADDITIONAL OPTIONAL INFORMATION	Comments:
*Number of sprockets:	
Diameter of sprocket:	
Or number of teeth:	
Carryway material:	
Slider bed or Wear strips?	
Material:	

GATES TPU
 9 Northwestern Drive Salem, NH 03079, U.S.A.
 Tel. +1 (603) 890-1515. / +1 (800) 394-4844.
 contact@gates.com
 www.gates.com/TPU

Application Engineering
 email: slo.apps@gates.com
 Tel. +1 (800) 505-8494