



TPU BELTS

THERMOPLASTIC POLYURETHANE

FLATCLEAN™ FOOD GRADE BELTING

FlatClean is a USDA approved, all-purpose urethane flat belt reinforced with Kevlar™ tensile members.

- Kevlar tensile members minimize belt stretch, reduce retensioning and extend belt life
- Made from a non-fraying, polyurethane jacket material with sealed edges that prevent ingress of microbes
- FC12 belt is for standard to high loads, particularly well suited for cleated belts
- The FC9 series allows for a 1" (25.4 mm) minimum pulley diameter
 - Two color appearance assures correct textured surface positioning for small pulley applications

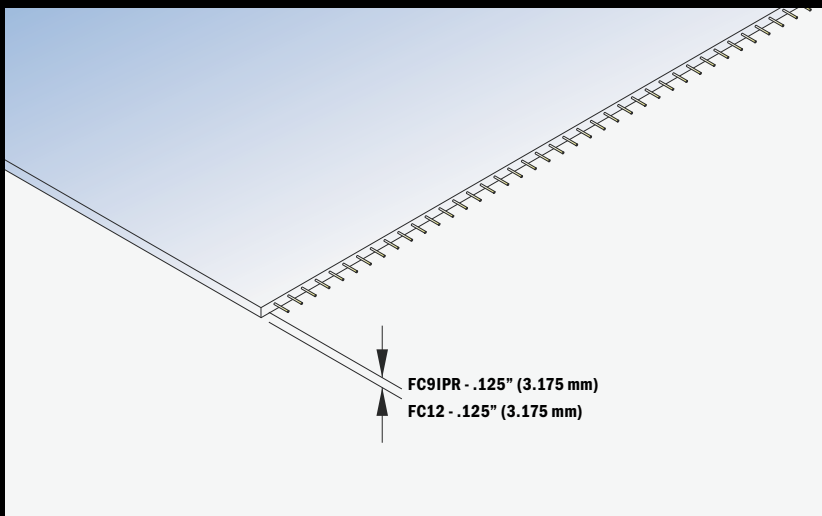

FEATURES

- Clean-in-place process appropriate
- Urethane material compatible with wash down environments
- Kevlar tension members provide high strength, low stretch
- Sealed edges and tension members prevent ingress of microbes
- USDA accepted for meat, poultry and dairy processing equipment
- Oil resistant

BENEFITS

- Reduce cleaning water usage and waste water disposal by 45%
- Reduce cleaning labor by 50%
- Fabricators can easily slit roll stock without striking tensile member

FLATCLEAN SPECIFICATIONS

SPECIFICATIONS	FC9		FC12				
	STANDARD		STANDARD		METAL DETECTABLE		
	METRIC	IMPERIAL	METRIC	IMPERIAL	METRIC	IMPERIAL	
Designator	FC9IPR		KV-FDA		KV-FMD		
Surface finish	Top	Smooth		Smooth, IP, IT, ST, CT		Smooth, IP, IT, ST	
	Running Side	Inverted Pyramid		Inverted Pyramid		Inverted Pyramid	
Thickness		3mm	0.125"	3mm	0.125"	3mm	0.125"
Hardness - Shore A	Top	90		95		95	
	Running Side	95		95		95	
Cords cm / in widths		10	2.5	8	2	8	2
Specific belt weight kg/m ²		2.8		3.8		4.1	
Specific belt weight lbs/in		0.048		0.065		0.07	
Specific belt stiffness N/mm		772		1296		1296	
Specific belt stiffness lbs/in		4410		7400		7400	
Min. Sprocket Dia. Service Temp above -4°C/25°F		26mm	1"	51mm	2"	76mm	3"
Min. Sprocket Dia. Service Temp below -4°C/25°F		51mm	2"	76mm	3"	100mm	4"
Min. Back Bend Dia. above -4°C / 25°F		51mm	2"	51mm	2"	76mm	3"
Min. Back Bend Dia. below -4°C / 25°F		76mm	3"	76mm	3"	100mm	4"
Service Temperature Range °C		-18° to 71°C		-18° to 71°C		-18° to 71°C	
Service Temperature Range °F		+0° to 160°F		+0° to 160°F		+0° to 160°F	
Ultimate Belt Strength (N/mm)				46		46	
Ultimate Belt Strength (lbs/inch)		203		265		265	
Min widths		125mm	5"	125mm	5"	125mm	5"
Color	Top	Medium Blue		PosiBlue, PosiWhite		PosiBlue	
	Running side	PosiBlue		PosiBlue, PosiWhite		PosiBlue	
FASTENING OPTIONS							
Max. Allowable Tension (1)		N/cm	lbs/inch	N/cm	lbs/inch	N/cm	lbs/inch
Platen Weld (Finger 20 mm x 70 mm)		53	30	85	48	65	37
Flexco® UX1SS Clipper® Wire Hooks		58	33	104	59	54	31
Flexco APF100 Alligator® Plastic Rivet		48	27	N/A	N/A	N/A	N/A
Flexco APF150 Alligator Plastic Rivet		N/A	N/A	60	34	N/A	N/A
Flexco RS62 Alligator Ready Set™ Staple		54	31	N/A	N/A	N/A	N/A
Flexco RS125 Alligator Ready Set Staple		N/A	N/A	90	51	54	31

(1) Max allowable set as the lower of 25% yield strength or 2% stretch of weld or splice

STANDARD WIDTHS	cm	45.7	61.0	76.2	81.28	91.44	121.9	152.4
	inch	18	24	30	32	36	48	60
FC12 Standard		N/A	x	x	x	x	x	x
FC12 Metal detectable		N/A	x	x	x	x	x	x
FC9		N/A	x	x	x	x	x	—

NORTH AMERICA
 Gates TPU
 9 Northwestern Drive
 Salem, NH 03079
 Tel. +1(800) 394-4844
 Email: contact@gates.com
EMEA
 Gates TPU GmbH
 Wermervon Siemens Strasse 2
 64319 Pfungstadt, Germany
 Tel. +49 (0) 6157-9727-0
 Email: sales-pfungstadt@gates.com
GATES.COM/TPU
 10/2021
